

Functional & Stylish
SPEEDRACK
 SINCE 1979

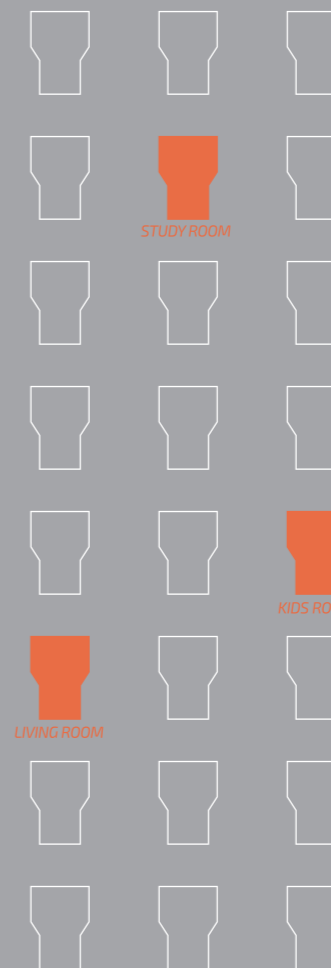

 **YOUNG JIN INDUSTRIES CO., LTD.**
1979

367-26, Daegotbuk-ro, Daegot-myeon, Gimpo-si, Gyeonggi-do, 10028, Korea
 TEL +82-31-984-3428 E-mail park@yjic81.com www.speedrack.co.kr

SPEEDRACK

Since 1979, Young Jin Industries Co., Ltd. has been a top manufacturer of metal angle racks in Korea. 'SPEEDRACK' has been keeping the number one brand power for 5 consecutive years with 80% market share. We are focusing on home furniture for home living space.

Boltless connection with a variety of transformation, modern design and nice finishing are attractive selling points of SPEEDRACK. All the products are 100% Made in Korea.

Our History

| | |
|--|--|
| <h3>2018</h3> <ul style="list-style-type: none"> Acquired ISO 9001 certificate Acquired ISO 14001 certificate Received 'Order of Industrial Service Merit from President in Small and Medium Business Meeting Acquired FSC COC certificate from International Forest Administration Association Released new product 'SPEEDRACK Change Up' Released new product 'SPEEDRACK Wire' Recognized as member of 'Korea Furniture Association' | <h3>2017</h3> <ul style="list-style-type: none"> Grand Prize in Quality Management in 2017 Global Standard Management Award Confirmed as venture company by Korea Technology Finance Corporation Designated as 'Small and Medium Company with Promising Export' by Ministry of SMEs and Startups, Gyeonggi Branch Received recognition on Research and Development department by Korea Industrial Technology Association Confirmed as company specialized in material and parts by Ministry of Trade, Industry and Energy Became regular member of INNOBIZ |
| <h3>2016</h3> <ul style="list-style-type: none"> Acquired 'Next-Generation World's Best Product' certificate from Ministry of Trade, Industry and Energy Acquired 'Export Frontier Company' certificate from Gyeonggi-do Received Grand Prize in 2016 Quality Management for 'Global Standard Management Award' Acquired 'Excellent Technical Evaluation Company' by NICE Information Service 'Small and Medium Business for INNOBIZ' by Ministry of SMEs and Startups Newly established Research and Development Department and acquired certificate from Korea Industrial Technology Association Selected as 'Excellent Job Creation Company' in Gyeonggi-do Newly established Gimpo plant and sales headquarter Launched new product, 'SPEEDRACK Multi-Cabinet' in Hyundai Home Shopping | <h3>2015</h3> <ul style="list-style-type: none"> Grand Prize in Quality Management in 2015 Global Standard Management Award Selected as 'Electronic Trade Frontier Company' in Gyeonggi-do |
| <h3>2014</h3> <ul style="list-style-type: none"> A Received excellence award in 2014 Global Standard Management Award Selected as 'HIT500' by Ministry of SMEs and Startups | <h3>2013</h3> <ul style="list-style-type: none"> Arranged Innovative Project plan Started active production of SPEEDRACK |
| <h3>2011</h3> <ul style="list-style-type: none"> Converted corporate to Youngjin Industry | <h3>2008</h3> <ul style="list-style-type: none"> Moved and expanded plants |
| <h3>1979</h3> <ul style="list-style-type: none"> Established Youngjin Angle | |

Awards & Certificates

| | | | |
|--|---|---|---|
|  <p>• ISO 9001 (Acquired Certificate in 2018)</p> |  <p>• ISO 14001 (Acquired Certificate in 2018)</p> |  <p>• FSC Certificate</p> |  <p>• Next-Generation World's Best Product Certificate</p> |
|  <p>• E1 Grade Certificate</p> |  <p>• 120kg Load Test Certificate (3 shelves)</p> |  <p>• 120kg Load Test Certificate (5 shelves)</p> |  <p>• Risk Assessment Certificate</p> |
|  <p>• Design Registration Certificate</p> |  <p>• Patent</p> |  <p>• Design Certificate</p> |  <p>• HIT500 Certificate</p> |
|  <p>• Excellent Job Creation Certificate</p> |  <p>• Excellent Technical Evaluation Certificate</p> |  <p>• Small and Medium INNOBIZ</p> |  <p>• Certificate of Regular Membership for Gyeonggi-do Export Association</p> |

LIVING BEYOND TECHNOLOGY

A reliable SPEEDRACK made with 40 years of know-how on material selection and convenient assembly is trying its best to provide affluent and convenient life.

Raw Materials

Laminated Eco friendly MDF (E1 grade)

Boltless Assembly Method

Powerful Assembly

Safe Storage Load

Our Technology

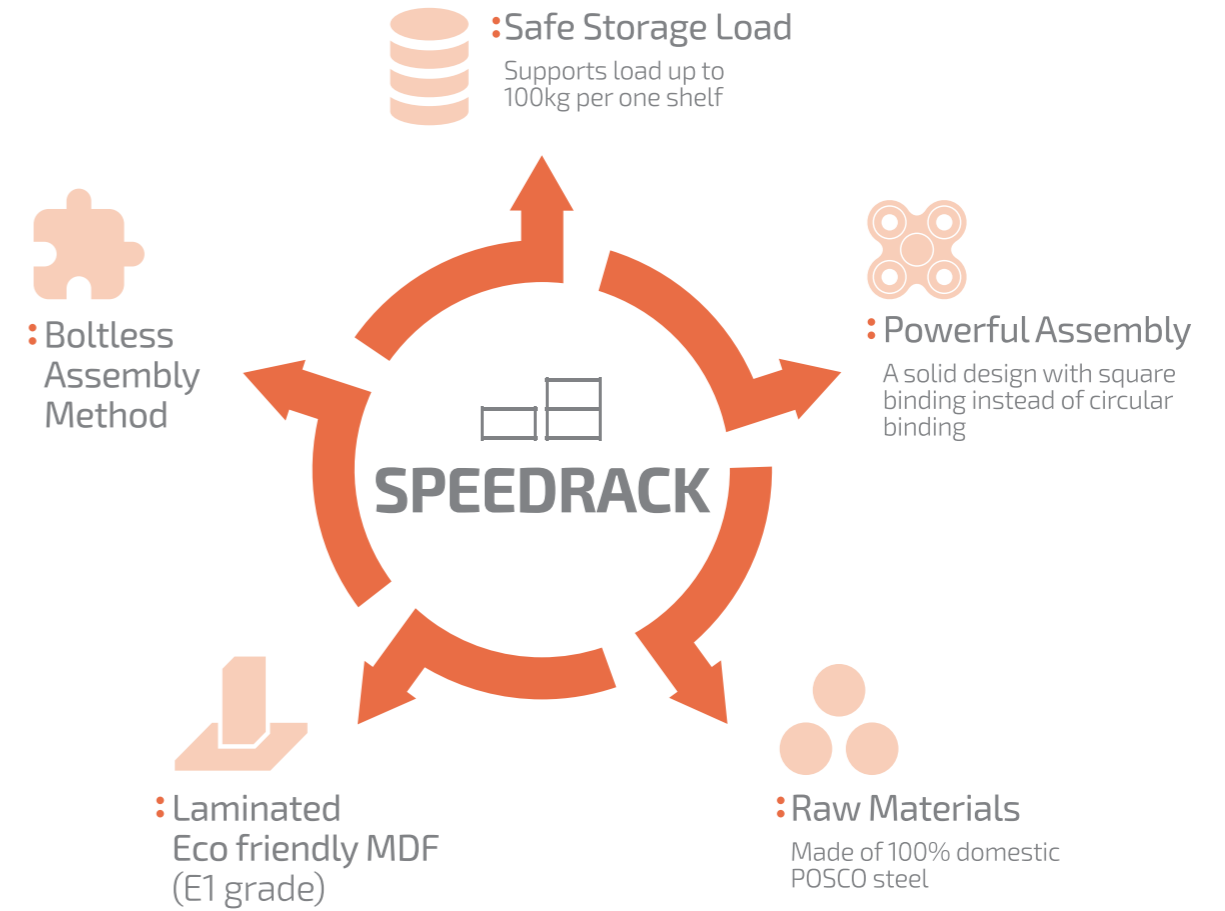

Steel / MDF(E1)



Features

- Steel of SPEEDRACK is made with powder coating method instead of general paint. The steel has high rust-resistance with 250°C surface heat treatment.
- Laminated MDF received E1 Grade in indoor environment rating. (Satisfies formaldehyde production rate standard)
- When laminated MDF is contaminated with water or solution, it can be easily cleaned.

Size Guide

- Width | 600, 700, 800, 900, 1000, 1100, 1200, 1500
- Depth | 300, 400, 500, 600, 700, 800, 900
- Height | 450, 900, 1350, 1800, 2250

Functional & Stylish

SPEEDRACK HOLELESS PRODUCTS

SPEEDRACK HOLELESS products help more practical and comfortable lifestyle with easy assembly and durability.

| | |
|---------------|----|
| ▼ Living Room | 08 |
| ▼ Bed Room | 10 |
| ▼ Wardrobe | 12 |
| ▼ Study Room | 14 |
| ▼ Kids Room | 16 |
| ▼ Kitchen | 18 |



Comfortable Life style SPEEDRACK

LIVING ROOM

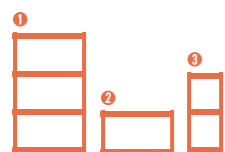

- ① W800 x D400 x H1350
- ② W800 x D400 x H450
- ③ W400 x D400 x H900



Cosy Life style
SPEEDRACK

BED ROOM

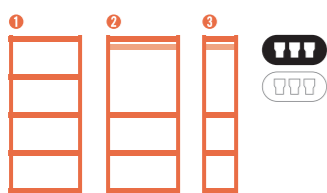

- 1 2 W800 x D400 x H1800
- 3 W400 x D400 x H1800

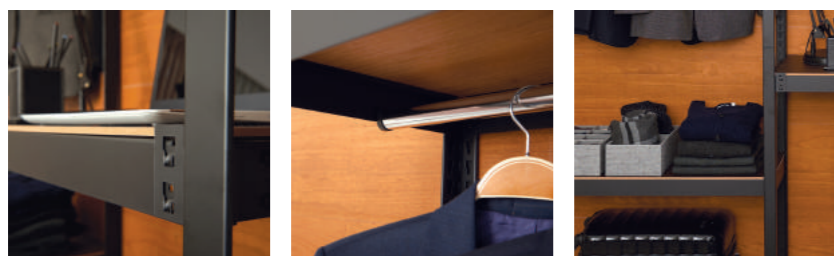

Functional & Stylish

SPEEDRACK



Luxury Life style SPEEDRACK
WARDROBE

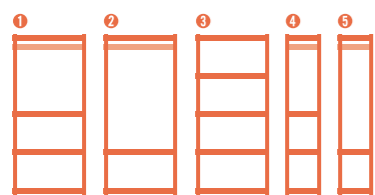

1 2 3 W800 x D400 x H1800
 4 5 W400 x D400 x H1800



Cosy Life style
SPEEDRACK

STUDY ROOM

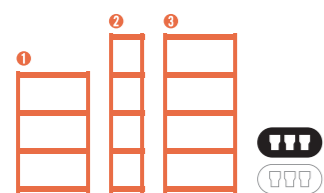

- ① W800 x D400 x H1350
- ② W400 x D400 x H1800
- ③ W800 x D400 x H1800





Happy Life style SPEEDRACK KIDS ROOM

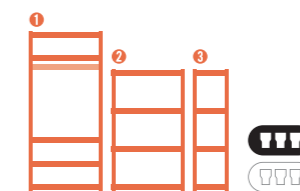

- ① W800 x D400 x H1800
- ② W800 x D400 x H1350
- ③ W400 x D400 x H1350





Healthy Life style
SPEEDRACK
KITCHEN

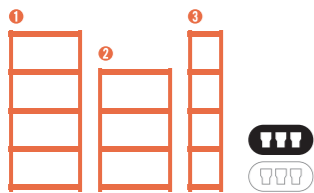

- ① W800 x D400 x H1800
- ② W800 x D400 x H1350
- ③ W400 x D400 x H1800

HOLELESS SINGLE BEST

※ One packing box

▼ SPEC - 5 SHELVES,
W800 D400 H1800(900+900)mm



| THICKNESS | BOARD | LOAD CAPA | |
|---------------|--------|----------------|-----------------|
| 1.6T(0.8+0.8) | 6mm | 100KG / SHELF | |
| NW | GW | 40FT Container | |
| 22.5KG | 23.5KG | Pallets | Without Pallets |
| | | 800 | 1,040 |

NOTE) Connection beam (IN & OUT) included

▼ SPEC - 4 SHELVES,
W800 D400 H1350(900+450)mm

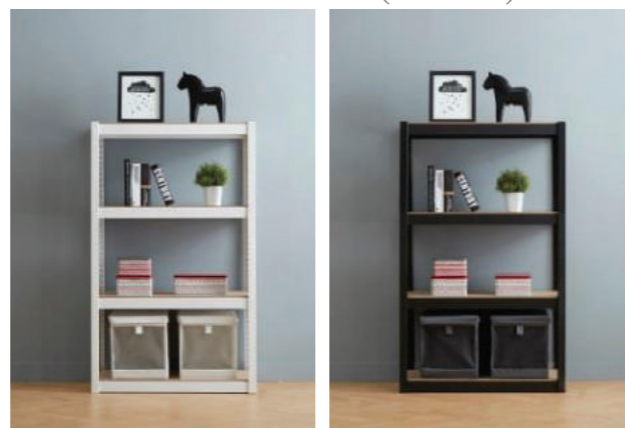

| THICKNESS | BOARD | LOAD CAPA | |
|---------------|--------|----------------|-----------------|
| 1.6T(0.8+0.8) | 6mm | 100KG / SHELF | |
| NW | GW | 40FT Container | |
| 19.5KG | 20.5KG | Pallets | Without Pallets |
| | | 800 | 1,200 |

NOTE) Connection beam (IN & OUT) included

▼ SPEC - 4 SHELVES W/Hanger,
W800 D400 H1800(900+900)mm



| THICKNESS | BOARD | LOAD CAPA | |
|---------------|-------|----------------|-----------------|
| 1.6T(0.8+0.8) | 6mm | 100KG / SHELF | |
| NW | GW | 40FT Container | |
| 20KG | 21KG | Pallets | Without Pallets |
| | | 800 | 1,150 |

NOTE) Connection beam (IN & OUT) included

▼ SPEC - 3 SHELVES W/Hanger,
W800 D400 H1800(900+900)mm



| THICKNESS | BOARD | LOAD CAPA | |
|---------------|--------|----------------|-----------------|
| 1.6T(0.8+0.8) | 6mm | 100KG / SHELF | |
| NW | GW | 40FT Container | |
| 16.5KG | 17.5KG | Pallets | Without Pallets |
| | | 800 | 1,350 |

NOTE) Connection beam (IN & OUT) included

I Small Model

▼ SPEC - 2 SHELVES,
W800 D400 H450mm



| THICKNESS | BOARD | LOAD CAPA |
|---------------|-------|---------------|
| 1.6T(0.8+0.8) | 6mm | 100KG / SHELF |
| NW | GW | |
| 9.5KG | 10KG | |

▼ SPEC - 3 SHELVES,
W800 D400 H900mm



| THICKNESS | BOARD | LOAD CAPA |
|---------------|--------|---------------|
| 1.6T(0.8+0.8) | 6mm | 100KG / SHELF |
| NW | GW | |
| 16KG | 16.5KG | |

▼ SPEC - 3 SHELVES,
W400 D400 H900mm



| THICKNESS | BOARD | LOAD CAPA |
|---------------|--------|---------------|
| 1.6T(0.8+0.8) | 6mm | 100KG / SHELF |
| NW | GW | |
| 12KG | 12.5KG | |

▼ SPEC - 4 SHELVES,
W400 D400 H1350(900+450)mm



| THICKNESS | BOARD | LOAD CAPA |
|---------------|-------|---------------|
| 1.6T(0.8+0.8) | 6mm | 100KG / SHELF |
| NW | GW | |
| 14.5KG | 15KG | |

HOLELESS COMBINATION BEST

※ Two packing boxes

■ SPEC - 5 SHELVES + 4(1+3) SHELVES W/HANGER, W800 D400 H1800(900+900)mm



| THICKNESS | BOARD | LOAD CAPA |
|---------------|-------|---------------|
| 1.6T(0.8+0.8) | 6mm | 100KG / SHELF |

NOTE) Connection beam (IN & OUT) included

■ SPEC - 5(4+1) SHELVES + 3 SHELVES W/HANGER, W800 D400 H1800(900+900)mm



| THICKNESS | BOARD | LOAD CAPA |
|---------------|-------|---------------|
| 1.6T(0.8+0.8) | 6mm | 100KG / SHELF |

NOTE) Connection beam (IN & OUT) included

■ SPEC - 4 SHELVES + 5(1+4) SHELVES, 4 SHELVES, W800 D400 H1350(900+450)mm | 5 SHELVES, W800 D400 H1800(900+900)mm



| THICKNESS | BOARD | LOAD CAPA |
|---------------|-------|---------------|
| 1.6T(0.8+0.8) | 6mm | 100KG / SHELF |

NOTE) Connection beam (IN & OUT) included

■ SPEC - 4(3+1) SHELVES W/HANGER + 4 SHELVES, 4 SHELVES W/HANGER, W800 D400 H1800(900+900)mm | 4 SHELVES, W800 D400 H1350(900+450)mm



| THICKNESS | BOARD | LOAD CAPA |
|---------------|-------|---------------|
| 1.6T(0.8+0.8) | 6mm | 100KG / SHELF |

NOTE) Connection beam (IN & OUT) included

TRANSFORMATION

SPEEDRACK with boltless assembly solution can be freely adjusted & transformed in the shape, size, height based on the user's need and can be utilized for multi purpose function.

5 SHELVES + 5 SHELVES

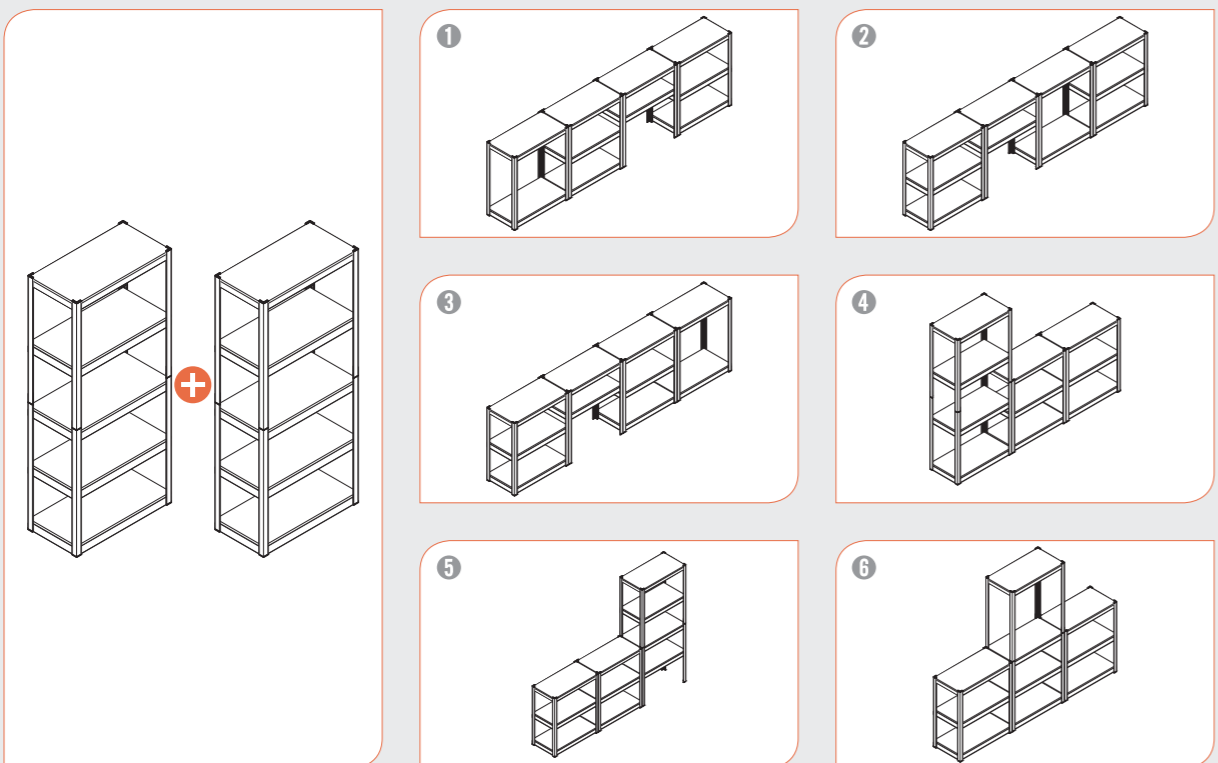

4 SHELVES + 4 SHELVES

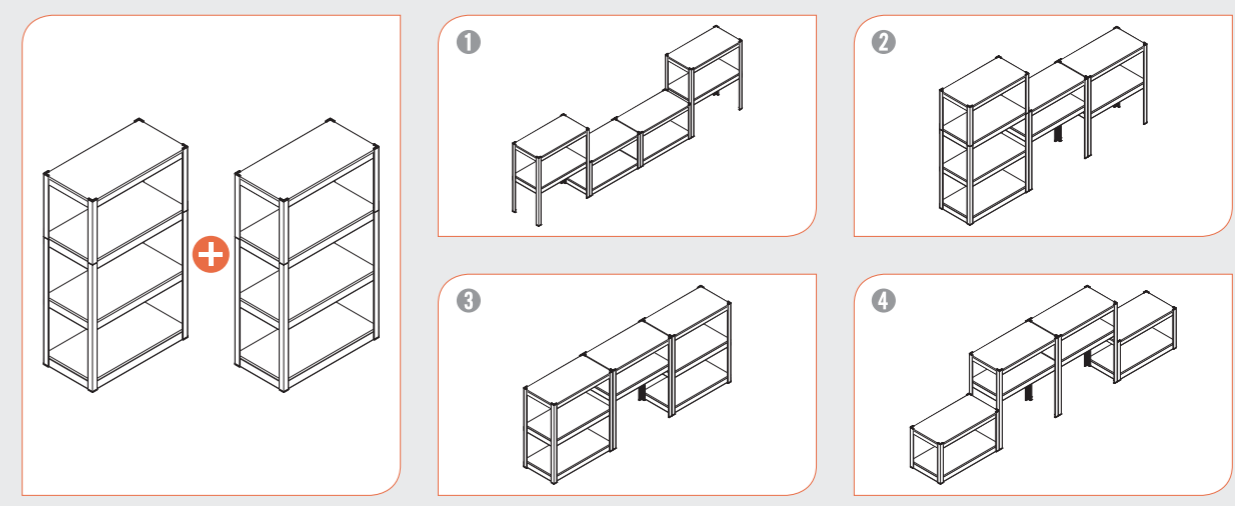

4 SHELVES + 5 SHELVES

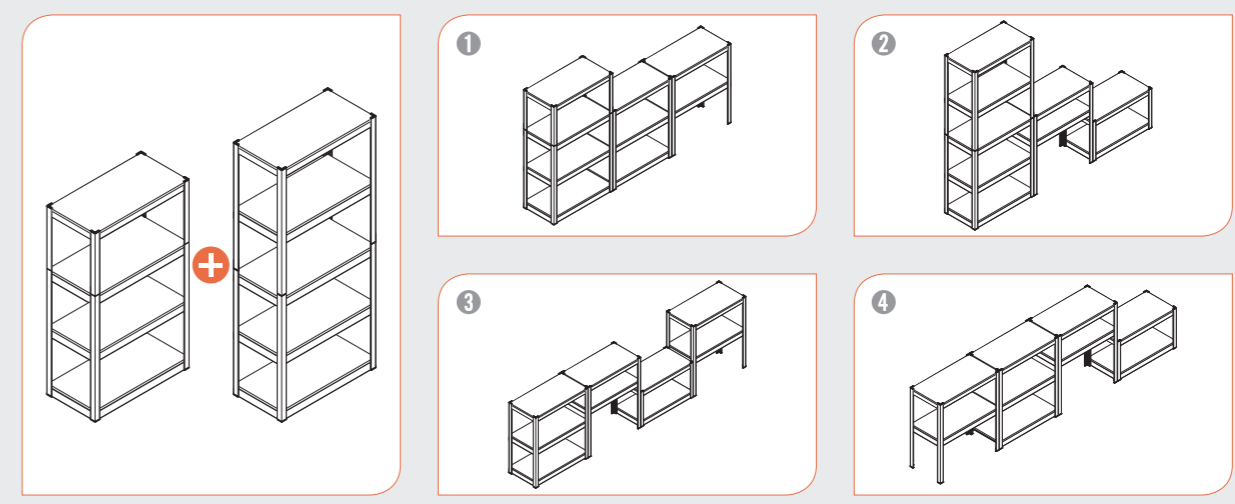

5 SHELVES + 4 SHELVES W/HANGER

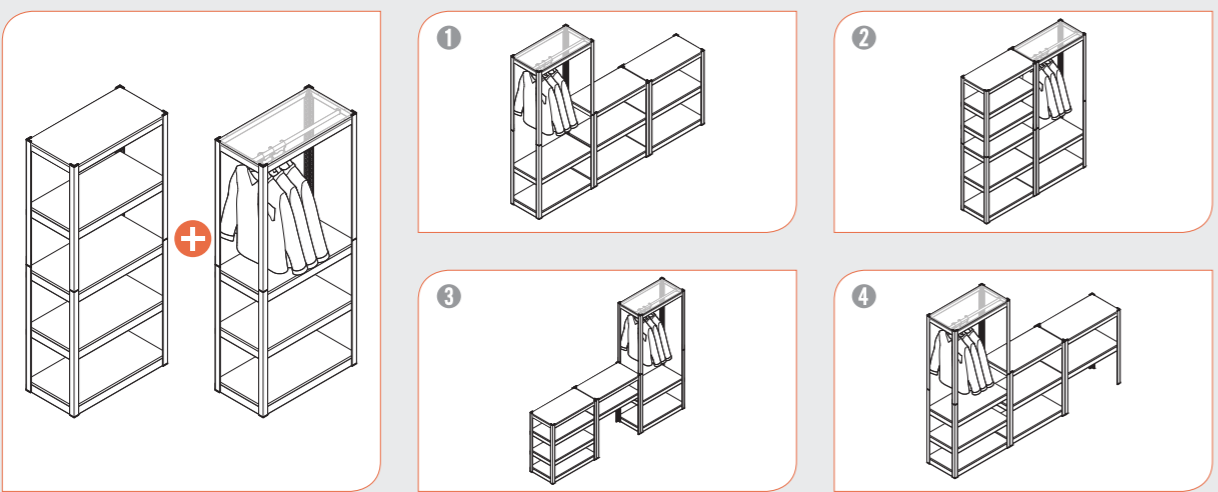

4 SHELVES W/HANGER + 4 SHELVES W/HANGER

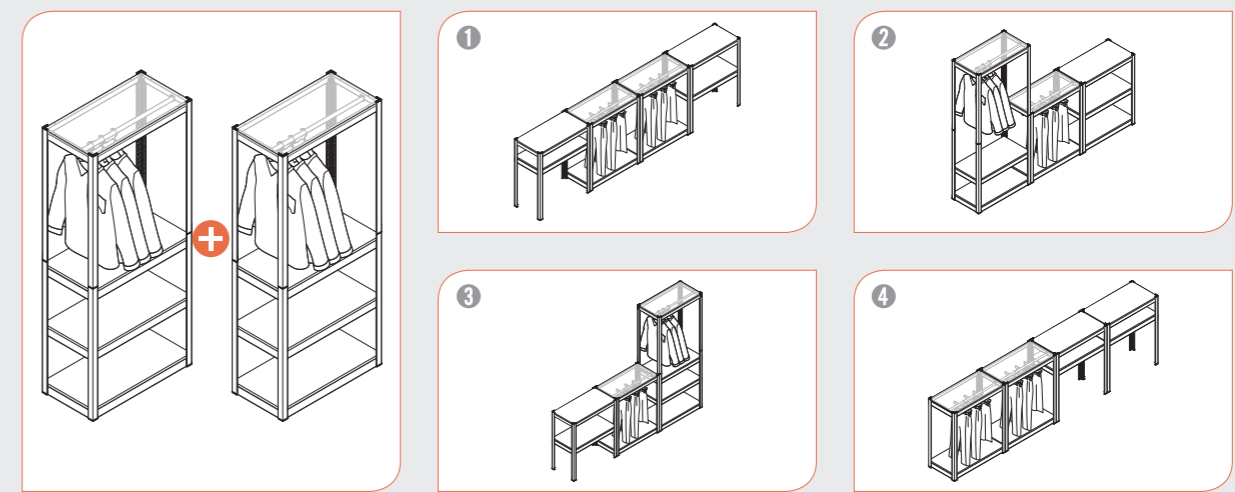

Applications of Transformation



• 5 SHELVES + 5 SHELVES



• 5 SHELVES + 4 SHELVES W/HANGER



• 5 SHELVES + 3 SHELVES W/HANGER



• 4 SHELVES W/HANGER + 4 SHELVES W/HANGER



• 5 SHELVES + 4 SHELVES (+1 EXTRA SHELF)



• 4 SHELVES + 4 SHELVES

ACCESSORIES OPTION +



① Mesh board ② Metal hook ③ S-hook ④ Transparent bracket ⑤ Level foot

VARIATIONS

The product can be customized in customer's taste by using various dimension options.



(Unit : mm)

| WIDTH | DEPTH | HEIGHT |
|-------|-------|--------|
| 600 | 300 | 450 |
| 700 | 400 | 900 |
| 800 | 500 | 1,350 |
| 900 | 600 | 1,800 |
| 1,000 | 700 | 2,250 |
| 1,100 | 800 | |
| 1,200 | 900 | |
| 1,500 | | |